

## InLine Mixer Type zoatec IL

### The clever development

for the mixing,  
dispersing and  
homogenising of  
liquid and  
semi-solid  
products

#### Functional principle and customer value

To develop the reliable Rotor-Stator functional principle by means of intelligent solutions is the background of the zoatec homogenisers:

**The zoatec InLine Mixer stands out here from all conventional systems due to its ingenious design.** Since the flow direction is turned into the opposite direction of the drive, **the zoatec homogeniser is completely accessible from the outside.**

The whole working area can be dismantled without disassembling a lot of pipelines. When a **mechanical seal** is used, it is not located on the homogeniser pressure side and as a consequence it has a comparable **longer service life.**

#### THE INNOVATION



The **GMP**-suitable design with its **CIP**- and **SIP**-ability meets the highest hygienic requirements. Furthermore, there is the option to implement conventional O-ring seals, molded seals, a single or a double acting mechanical seal, without modifying any components. In this way it is easily possible to carry out subsequent adaptations. The necessary drive capacity can be optimally adjusted to the products and required throughputs.

Standard motors are delivered in a high energy efficiency class and are based on the product range of nominal motors.

It is at any time possible to visit our well-equipped **CPC (Customer Process Centre)** and to test the advantages of the zoatec InLine Mixer on site.

## Technical data

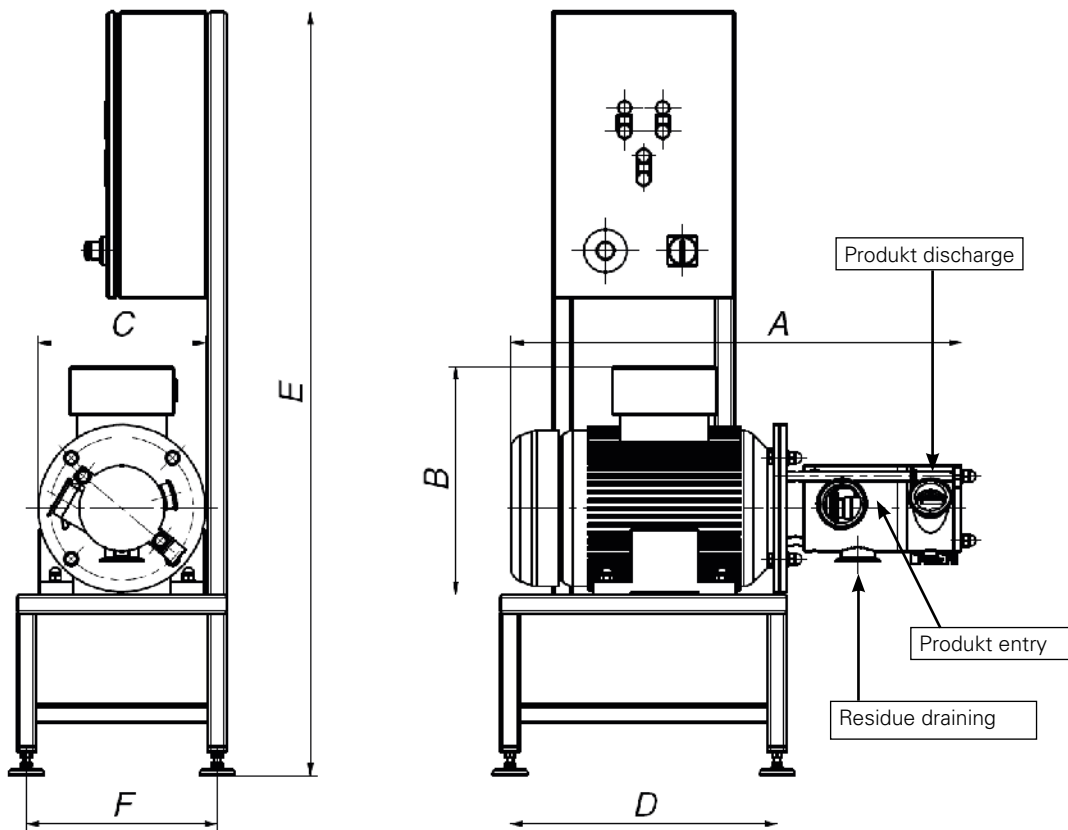

Size Type zoatec IL	Ø [mm]	Capacity [kW]	A	B	C	D	E	F	Weight [kg]
1	100	7,5	650	350	300	400	1700	350	130
2	160	18,5	900	420	350	600	1700	400	250
3	180	30,0	950	460	350	600	1700	400	350
4	230	75,0	1250	630	550	800	1700	650	700

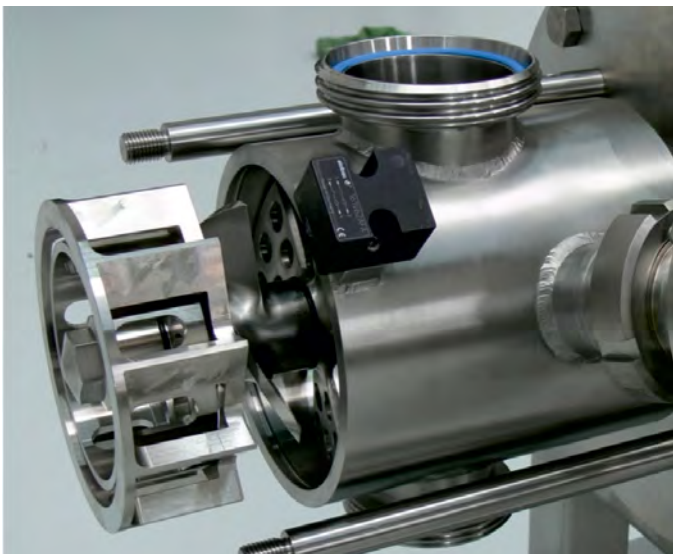

Easily accessible zoatec homogeniser